



# WiMAX Outdoor Router

## User Manual

Version 1.05

Applies to:

RUT723, RUT725, RUT735 and RUT738

## LEGAL NOTICE

Copyright © 2012 TELTONIKA Ltd. All rights reserved. Reproduction, transfer, distribution or storage of part or all of the contents in this document in any form without the prior written permission of TELTONIKA Ltd is prohibited. The manufacturer reserves the right to modify the product and manual for the purpose of technical improvement without prior notice.

**Other product and company names mentioned herein may be trademarks or trade names of their respective owners.**

## ATTENTION



Before using the device we strongly recommend reading this user manual first.



Do not rip open the device. Do not touch the device if the device block is broken.



Device should be serviced only by qualified personnel.



All wireless devices for data transferring may be susceptible to interference, which could affect performance.



The device is water-resistant (IP65) and can be mounted outdoor, though power adapter must be kept dry.

# Table of contents

<b>LEGAL NOTICE</b> .....	<b>2</b>
<b>ATTENTION</b> .....	<b>2</b>
<b>TABLE OF CONTENTS</b> .....	<b>3</b>
<b>SAFETY INFORMATION</b> .....	<b>4</b>
<b>DEVICE SERVICE</b> .....	<b>5</b>
<b>PRODUCT OVERVIEW</b> .....	<b>6</b>
INTRODUCTION.....	6
PACKAGE CONTENTS .....	6
SYSTEM REQUIREMENTS .....	6
<b>HARDWARE INSTALLATION</b> .....	<b>7</b>
CONNECTING DEVICE .....	7
MOUNTING DEVICE .....	8
<b>WEB GUI OVERVIEW</b> .....	<b>9</b>
CONNECTING TO THE WEBUI .....	9
WEBUI STRUCTURE .....	10
STATUS.....	10
NETWORK .....	11
<i>IP address</i> .....	11
<i>DHCP server</i> .....	11
<i>Dynamic DNS</i> .....	12
<i>OpenVPN</i> .....	13
FIREWALL .....	14
<i>Port forwarding</i> .....	14
<i>Mac filtering</i> .....	15
<i>IP filtering</i> .....	16
<i>Demilitarization zone</i> .....	17
ADMINISTRATION.....	17
<i>Settings</i> .....	17
<i>Firmware</i> .....	18
<i>Password</i> .....	18
ABOUT.....	18
<b>TROUBLESHOOTER:</b> .....	<b>19</b>
UNDER WINDOWS 7 .....	19
UNDER MAC OS.....	20
UNDER LINUX (GNOME 3).....	21
<b>TECHNICAL SPECIFICATIONS:</b> .....	<b>22</b>
ELECTRICAL, MECHANICAL & ENVIRONMENTAL:.....	22

## SAFETY INFORMATION

In this section you will be introduced on how to use a WiMAX Outdoor Router safely. You have to be familiar with the safety requirements before using the device! We suggest you to adhere to the following recommendations in order to avoid personal injuries and or property damage.



The device is intended for supply from a Limited Power Source (LPS) that power consumption should not exceed 15VA and current rating of overcurrent protective device should not exceed 2A.



The highest transient overvoltage in the output (secondary circuit) of used PSU shall not exceed 71V peak.



The device can be used with the Personal Computer (first safety class) or Notebook (second safety class). Associated equipment: PSU (power supply unit) (LPS) and personal computer (PC) shall comply with the requirements of standard EN 60950-1.



Do not mount or serve device during a thunderstorm.



Device is mounted in limited access areas.



To avoid mechanical damages to the device it is recommended to transport it packed in a damage-proof pack.



**Protection in primary circuits of associated PC and PSU (LPS) against short circuits and earth faults of associated PC shall be provided as part of the building installation.**

This automatic two pole protective device disconnects all the associated equipment (fig 1). To disconnect the device plug off the AC-DC power adapter from the wall outlet or power strip. The gap between contacts should be no less than 3mm.

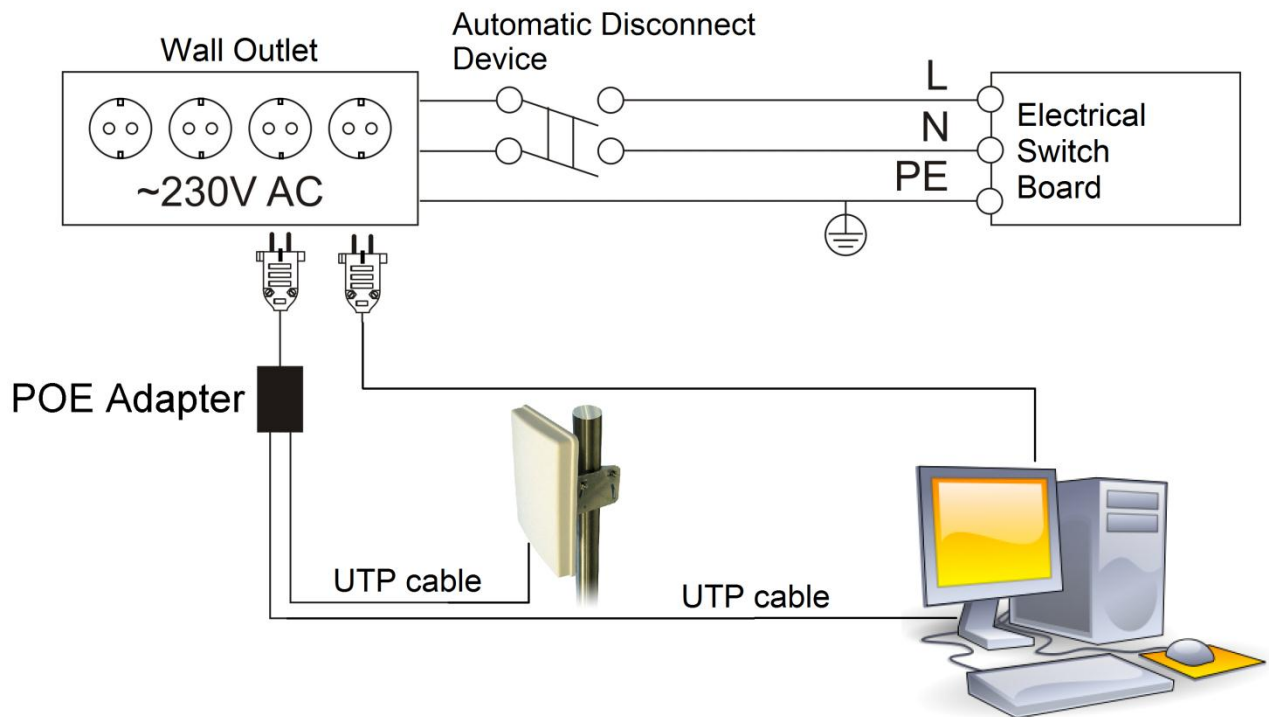

*1 Figure: Building installation scheme*

## Device service

Signal level of the device depends on the working environment. In case the device starts working insufficiently, please refer to qualified personnel in order to repair this product.

There are no exchangeable parts within the device including 2A quick acting fuse.

Device should be serviced only by qualified personnel. Opening the device will void the warranty for this product. We recommend forward it to a repair center or to the manufacturer.

Labels with product information (serial number and MAC address) can be found on the bottom side of the device as well as on the packaging.

## PRODUCT OVERVIEW

### Introduction

Teltonika RUT723, RUT725, RUT735 and RUT738 are outdoor routers offering high speed data rate connectivity to the WiMAX networks. Router is compliant with IEEE802.16e-2005 WiMAX Wave 2. 10/100 Base-T interface and integrated DHCP server allow easy connection to any device with Ethernet cable. Teltonika outdoor WiMAX router is ideal for distant locations. High gain MIMO antenna improves coverage and pole mounting kit ensures stable signal conditions. Included POE adapter allows the device to function with only Ethernet cable connected.

### Package contents

WiMAX Outdoor Router
<ul style="list-style-type: none"><li>• WiMAX Outdoor Router</li><li>• Pole mounting kit</li><li>• POE Adapter</li><li>• 2 x LAN cable</li><li>• Waterproof RJ45 connector kit</li><li>• Quick Start Guide</li></ul>

**Note:** The provisioning information is provided by your service provider, therefore any questions regarding connectivity problems should be addressed to it.

**Note:** If any of the components are missing or damaged, please contact the retailer or reseller from which this product was purchased.

**Note:** Using a not IEEE 802.3af-2003 compliant POE adapter with the WiMAX Outdoor Router will cause damage and void the warranty for this product.

### System requirements

- Wired network connection.
- Windows XP, Windows Vista, Windows 7, MAC OS X, or a Linux-based operating system.
- A web browser must have a flash player plug-in (version 10 or higher) in order to access the Web GUI for network configuration.

## Hardware installation

### Connecting device

Device has included waterproof RJ45 connector. Use it together with LAN cable and assemble as is shown in the picture below. To connect LAN cable to the router:

1. Plug cable into RJ45 socket
2. Tighten the screw around RJ45 socket
3. Tighten the nut around LAN cable



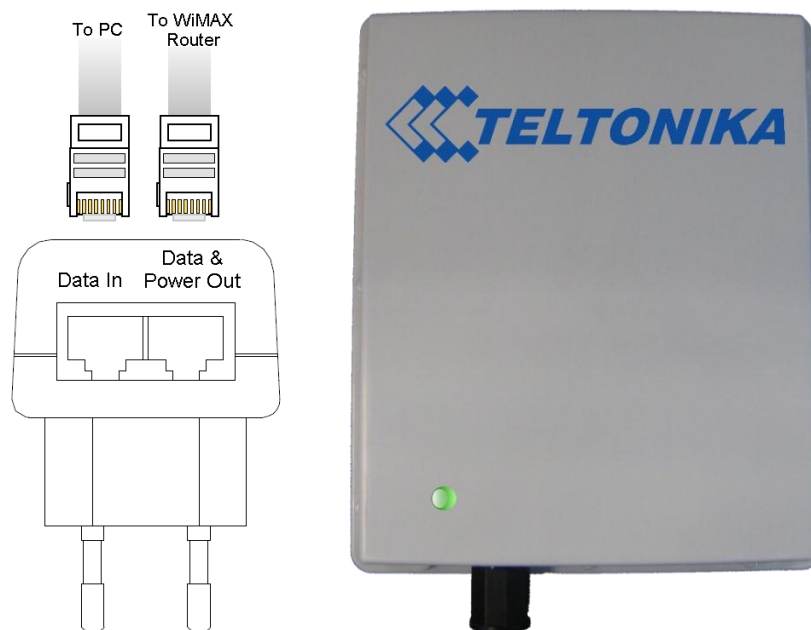

Device is powered from included POE adapter. Use LAN cables and connect Outdoor WiMAX Router to POE adapter's **"Data & Power Out"** port. Connect **"Data In"** port to your computer or switch. Plug POE adapter into AC socket to power the device on. Green light on the bottom left corner of the Outdoor Router (just above RJ45 socket) indicates that device is powered.

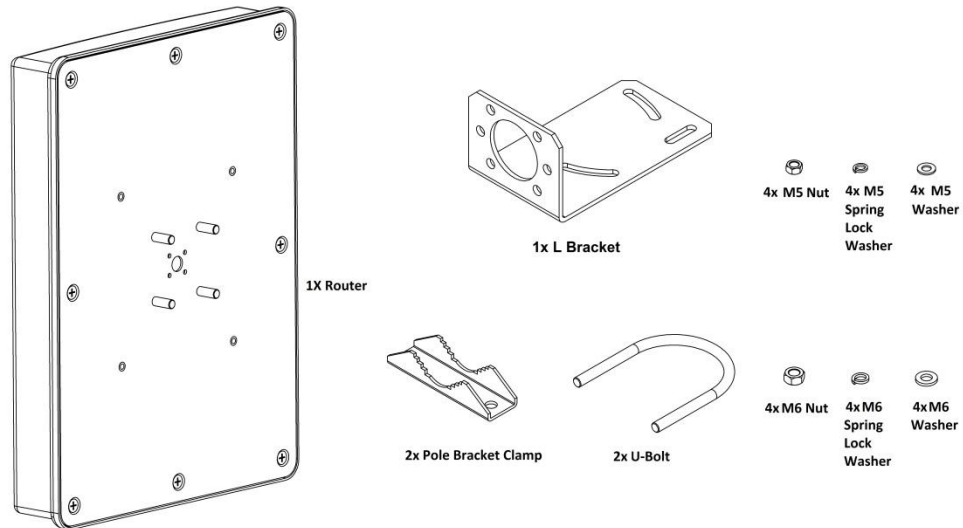

## Mounting device

Device pole mounting kit contains these elements:

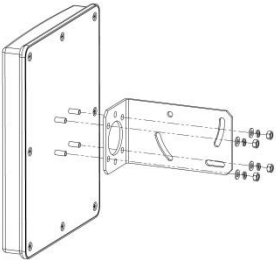
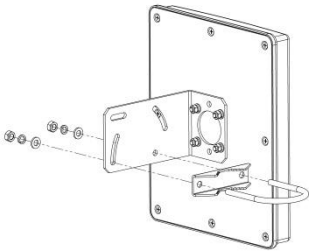

STEP 1	STEP 2	STEP 3
		
<p>Fix "L" bracket to the router</p>	<p>Assemble pole bracket clamp and "U" bolt on a pole</p>	<p>Adjust right direction and tightened the nuts.</p>

Device position and angle of antenna has big impact on performance. By monitoring **Status** window in WebUI try to find a location with best signal quality.

## Web GUI OVERVIEW

In this section you will be briefly introduced to our user interface.

**Note:** we use an intuitive tool tip system in our web user interface which displays additional data for the user. To see this data hover your mouse cursor above the field. Also, if the frame of the field becomes red, it usually means that the data in the field is incorrect, in this case look into red tool tip for more information.

### Connecting to the WebUI

To connect to the configuration web page do the following steps:

1. Make sure that IP address is set to be obtained automatically via DHCP on your computer.
2. Type **192.168.0.1** to your favorite internet browser. Skip the step 2 if the password is disabled.
3. Window asking for authentication will pop up. Enter your username and password (default: username: user, password: user) and press enter.

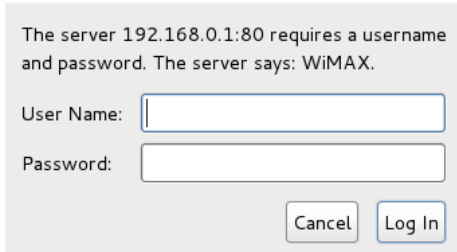

4. Status window will appear in a few seconds:

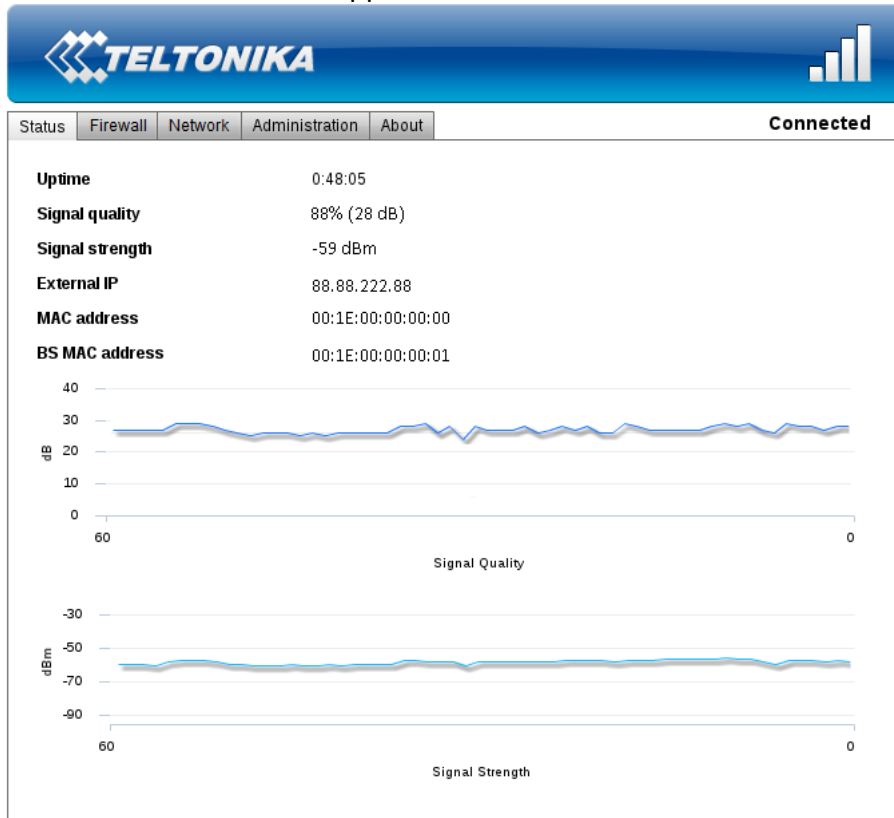

## WebUI structure

Our modern web user interface provides you with all the tools needed within the five main pages: **Status, Network, Firewall, Administration, About.**

### Status

Status	Firewall	Network	Administration	About
<b>Uptime</b>			0:48:05	
<b>Signal quality</b>			88% (28 dB)	
<b>Signal strength</b>			-59 dBm	
<b>External IP</b>			88.88.222.88	
<b>MAC address</b>			00:1E:00:00:00:00	
<b>BS MAC address</b>			00:1E:00:00:00:01	

*Status page*

The status page consists of 6 properties that define the current state of the WiMAX Outdoor Router:

1. **Uptime** – amount of time since the last reboot (or plug in).
2. **Signal quality** – the quality of a signal in percents (and decibels).
  - <30% poor
  - >30% <50% decent
  - >50% <90% good
  - >90% very good

**Note:** signal quality depends on the distance between the device and the base station, plus other factors: interference with other devices, etc.

3. **Signal strength** – the strength of the signal in dBm.
4. **External IP** – IP which was assigned by the base station to your device.
5. **MAC address** – physical address of the WiMAX connection module.
6. **BS MAC address** - physical address of the base station.

## Network

Network settings page allows the user to change the IP address, net mask and DHCP server settings.

### IP address

IP address	DHCP server	Dynamic DNS	OpenVPN
<b>LAN configuration</b>			
IP address	<input type="text" value="192.168.0.1"/>		
Netmask	<input type="text" value="255.255.255.0"/>		
<input type="button" value="Apply"/>			

*IP address settings page*

**IP address** – IP address of the router.

**Netmask** – mask used to divide IP address into subnets.

### DHCP server

Dynamic Host Configuration Protocol (DHCP) is a network protocol that enables a server to automatically assign an IP address to a computer from a defined range of numbers configured for a given network.

IP address	DHCP server	Dynamic DNS	OpenVPN
<b>DHCP server settings</b>			
Enable	<input checked="" type="checkbox"/>		
First IP address	<input type="text" value="192.168.0.1"/>		
No. of users	<input type="text" value="200"/>		
Lease time	<input type="text" value="6000"/>		
<input type="button" value="Apply"/>			

*DHCP server form*

**Enable** – check to enable the DHCP server.

**First IP address** – First IP from the range to be leased.

**No. of users** – number of IP addresses to be leased.

**Lease time** – time after the leased IP expires.

## Dynamic DNS

Dynamic DNS (DDNS) is a domain name service allowing to link dynamic IP addresses to static hostname. To start using this feature firstly you should register to DDNS service provider.

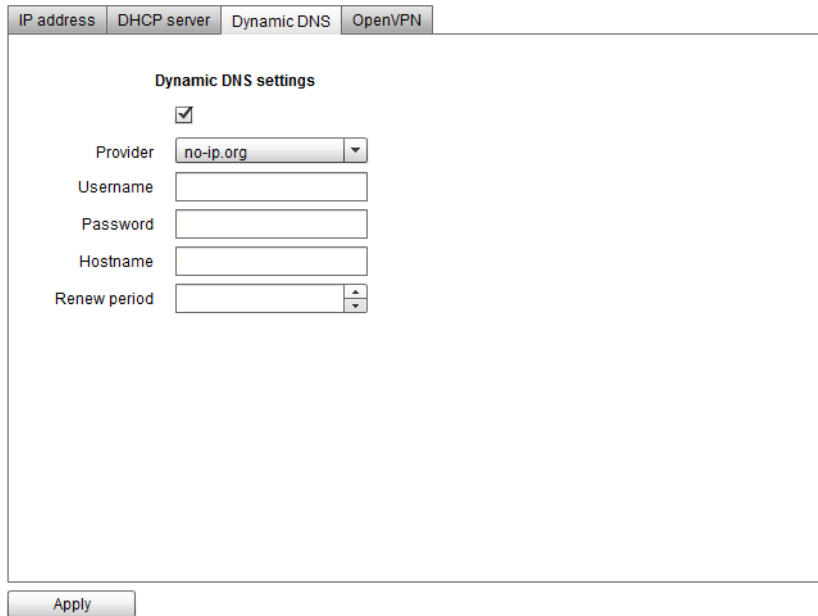

The image shows a software interface with four tabs: "IP address", "DHCP server", "Dynamic DNS", and "OpenVPN". The "Dynamic DNS" tab is selected. Below the tabs is a form titled "Dynamic DNS settings". The form contains a checked checkbox, a "Provider" dropdown menu with "no-ip.org" selected, and four text input fields for "Username", "Password", and "Hostname". The "Renew period" field is a spinner control. An "Apply" button is located at the bottom left of the form area.

*DDNS form*

**Provider** – your dynamic DNS service provider selected from the list.

**Username** – name of the user account.

**Password** – password of the user account.

**Hostname** – domain name that you will be able to use instead of your IP address.

**Renew period** – time interval to check if IP address of the device have changed.

## OpenVPN

VPN (virtual private network) is a secure network that provides remote offices or traveling users an access to a central organizational network.

IP address DHCP server Dynamic DNS OpenVPN

**General settings**

Enable OpenVPN

VPN mode P2P Server

Protocol UDP

LZO compression

**Local network settings**

Local tunnel IP 10.8.0.2

**Remote network settings**

Endpoint IP 84.15.196.36

Tunnel IP 10.8.0.1

Network IP 192.168.99.0

Network mask 255.255.255.0

**Keep alive settings**

Enable

Interval 10

Timeout 60

**Static key**

Select key file

Upload key file

Download key file

Apply

OpenVPN form

### General:

**Enable OpenVPN** – enables VPN functionality.

**VPN mode** – changes VPN mode **Client/Server**.

**Protocol** – use **TCP** or **UDP** for transmitting packets.

**LZO compression** – check the box to enable fast adaptive LZO compression.

### Network:

**Local tunnel IP** – specifies the IP address of the local VPN tunnel endpoint.

**Endpoint IP** – specifies server IP address.

**Tunnel IP** – specifies the IP address of the remote VPN tunnel endpoint.

**Network IP** – specifies the remote network IP.

**Network mask** – specifies the remote network subnet mask.

### Keep alive:

**Enable** – turns on “Keep alive” feature.

**Interval** – specifies time interval to check if VPN connection is still alive.

**Timeout** – specifies time span for the network to respond.

## Firewall

Firewall page lets you configure firewall settings to meet your requirements. It includes port-forwarding, MAC filtering and IP filtering

### Port forwarding

Port forwarding is the process of translating the address and port number of a packet to a new destination.

Follow these steps to add a port-forwarding rule:

1. **Enable** – check to enable the Port forwarding.
2. Press the **+** button.

Name	Protocol	External Port	Destination IP	Destination Port
PPTP	tcp	1723	192.168.0.8	1723

Port forwarding form

The following port-forwarding rule creation window will pop-up. Choose a rule type (single port or port range) and fill the fields in a window to define your rule:

- **Predefined rule** – select from a list of most common rules.
- **Name** – the name of the rule that will be visible in the list of your defined rules.
- **External port from/to** – external port range to be redirected to an identical internal port range.
- **External port** – external port to be redirected to **Internal port**.
- **Internal port** – port used by the destination device to receive data.
- **Protocol** – protocol in which rule operates.
- **Destination IP** – the address of the device to which all the data coming to the selected external ports is forwarded to.

Field	Value
Rule Type	Single port
Predefined rule	-
Name	Single forward #1
External port	80
Internal port	80
Protocol	TCP/UDP
Destination IP	192.168.0.156

Field	Value
Rule Type	Port range
Predefined rule	-
Name	Port Range forward #1
External port from	80
External port to	86
Protocol	TCP/UDP
Destination IP	192.168.0.156

New port-forwarding rule windows

3. Press **OK** button to accept the rule.
4. Press **Apply** to save the rules to the configuration.

## Mac filtering

MAC filtering is a security access control method used to determine access to the network by physical address.

Follow these steps to add a MAC filtering rule:

1. **Enable** – check to enable the MAC filtering.
2. Press the **+** button.

Name	MAC address	Filtering type	Chain
MAC block #1	00:86:40:99:00:13	DENY	FORWARD
MAC block #1	00:86:40:99:00:13	DENY	INPUT

*Mac filtering form*

3. The following MAC filtering rule creation window will pop-up.

**New MAC filtering rule** [X]

Name:

Filtering type:

MAC address:

*New MAC filtering rule window*

- **Name** – MAC filtering rule name.
  - **MAC address** – physical address that you want to block from connecting to and/or through the router.
4. Press **OK** to add the rule.
  5. After adding all the rules that you needed, press **Apply** to save the rules to the configuration.

## IP filtering

IP filtering is a security access control method used to determine access to the network by IP address.

Follow these steps to add an IP filtering rule:

1. **Enable** – check to enable the IP filtering.
2. Press the **+** button.

Name	Ip address	Chain
IP block #1	192.168.0.9	INPUT
IP block #1	192.168.0.9	FORWARD

IP filtering form

3. The following IP filtering rule creation window will pop-up.

New IP filtering rule

Name: IP block #1

Ip address: 192.168.0.123

OK Cancel

New IP filtering rule window

- **Name** – IP filtering rule name.
  - **IP address** – IP address that you want to block from connecting to and/or through the router.
4. Press **OK** to add the rule.
  5. After adding all the rules that you needed, press **Apply** to save the rules to the configuration.

## Demilitarization zone

In computer networks, a DMZ (demilitarized zone) is a computer host or small network inserted as a "neutral zone" between a private network and the outside public network.

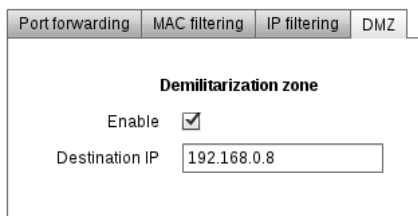

DMZ page

To set up DMZ, click the **Enable** checkbox and put in IP address of your destination in the **Destination IP** text field.

## Administration

Administration page allows you to change the language of the WebUI, disable radio connection, reboot the router, save firmware to your computer (in a binary file format) or update it with the newer version. In addition, you can set up a new password for WebUI connection.

### Settings

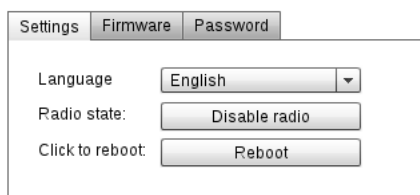

Settings page

**Language** – select a language from the drop down list.

**Radio state** – disables or enables radio (WiMAX) connection.

**Reboot button** – click to reboot this device. You will have to wait for a few seconds until it boots up again.

## Firmware

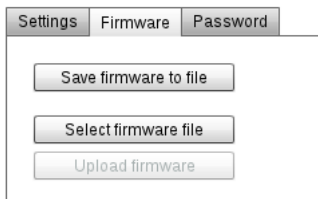

Firmware page

**To save firmware:** click [Save firmware to file](#) and at the following dialog browse to the directory you want to place binary file.

**To update firmware:** click [Select firmware file](#) and at the following dialog window select firmware file (note: file must be named `firmware.bin`). To start updating click: [Update firmware](#). This process usually takes 5 to 10 minutes.

**Note:** A firmware backup is only suitable for the device from which it was downloaded. If a firmware backup is uploaded to another router, that device will malfunction.

## Password

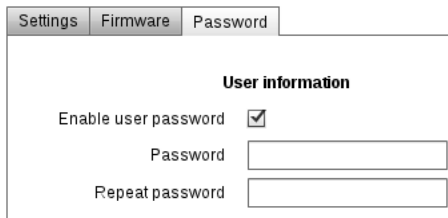

To set up or change a password check [Enable user password](#) and write a new one into two fields bellow. To disable user password simply uncheck [Enable user password](#) checkbox. You must click [Apply](#) if you want to save any of these to configuration.

**Note:** it is strongly not recommended to disable user password if a router is reachable from Local area network

## About

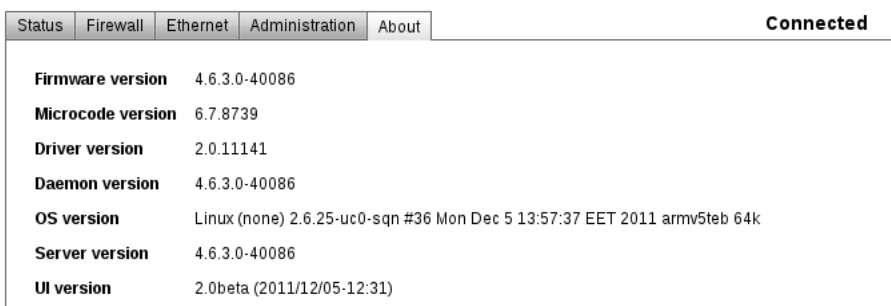

About page

The About page displays the versions of your firmware and software that are currently running on your device. This helps you decide whether or not you need to update your firmware.

**Note:** The last part in the OS version string refers to the sector size (64 kilobytes in this case) of the flash memory. It is important that the firmware you update is made for the same flash sector size as the flash memory in the device.

## Troubleshooter:

Q: I think my router is not working: can not acquire connection and WebUI is not reachable.

A1: Check if green LED indicating that device is powered is lit on the bottom left corner of the Outdoor Router (just above RJ45 socket). If not, check if PoE adapter is plugged into AC socket and that it is connected by Ethernet cable to the device.

A2: Check if IP address is set to be obtained automatically via DHCP.

Follow these steps:

### Under Windows 7

- Go to **Control panel ->Network and internet -> Network sharing center -> change adapter settings.**
- Right click on a Local Area Connection which uses WiMAX Outdoor Router for connecting to the internet and click **Properties.**

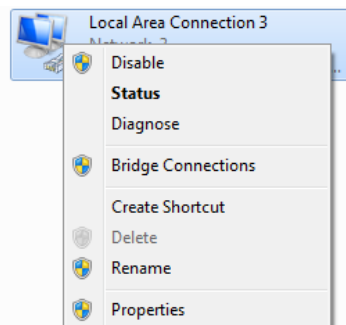

- Check **Internet Protocol IPv4 (TCP/IP)** and click **Properties.**

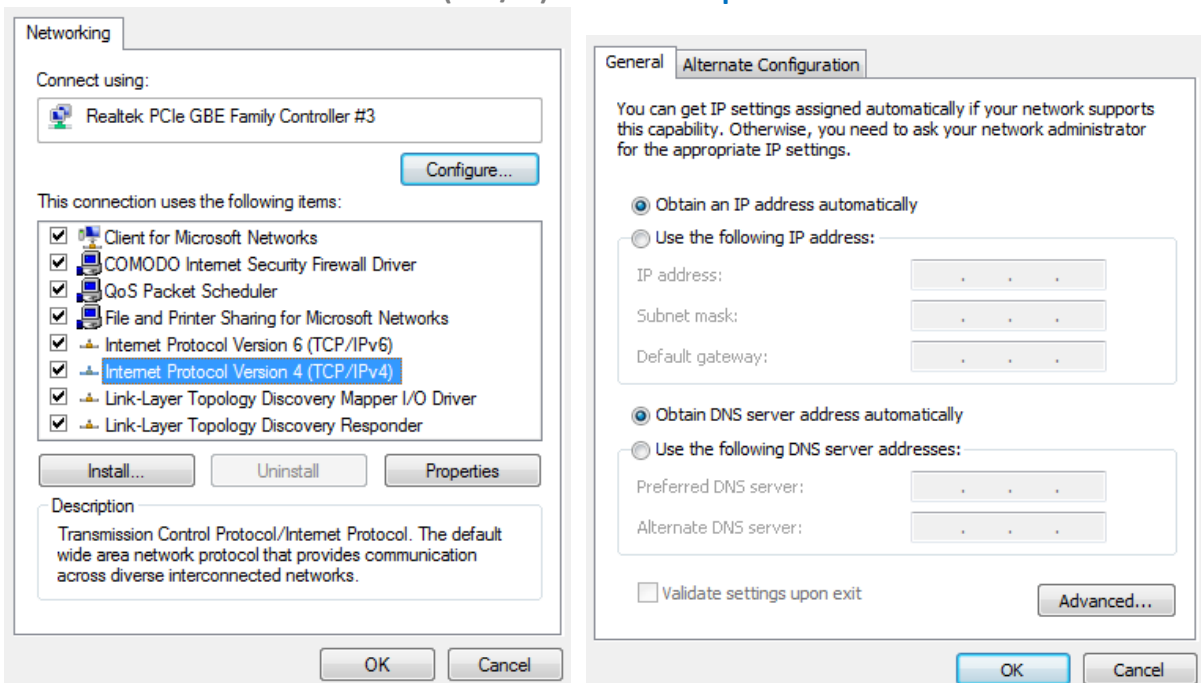

- Make sure that **Obtain IP address automatically** is checked in the **General** settings.
- Click **OK**

## Under MAC OS

- Click on the Apple Menu and select **System Preferences**



- In the Internet & Network section, click on the **Network** icon.
- Select **Built-in Ethernet**.

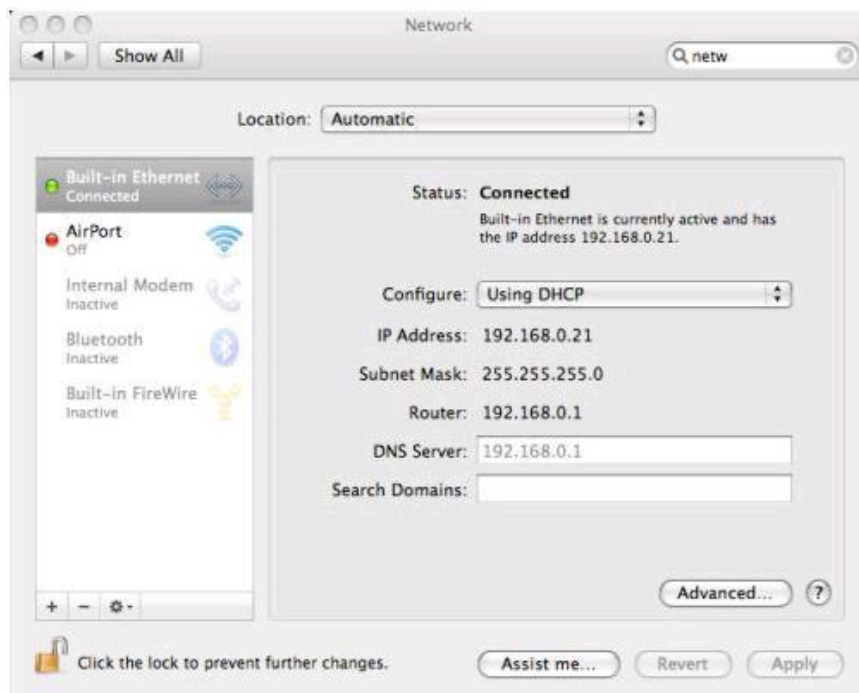

- Click on **Advanced**.
- In the TCP/IP tab, ensure that **Configure** is set to **Using DHCP**.
- Select the DNS tab. Ensure that DNS servers and Search Domains are empty.
- Click OK.

## Under Linux (GNOME 3)

- Click on network interfaces icon in activity bar
- Select **Network Settings**



- Click **Configure...** to open network connection properties.
- Go to IPv4 tab.

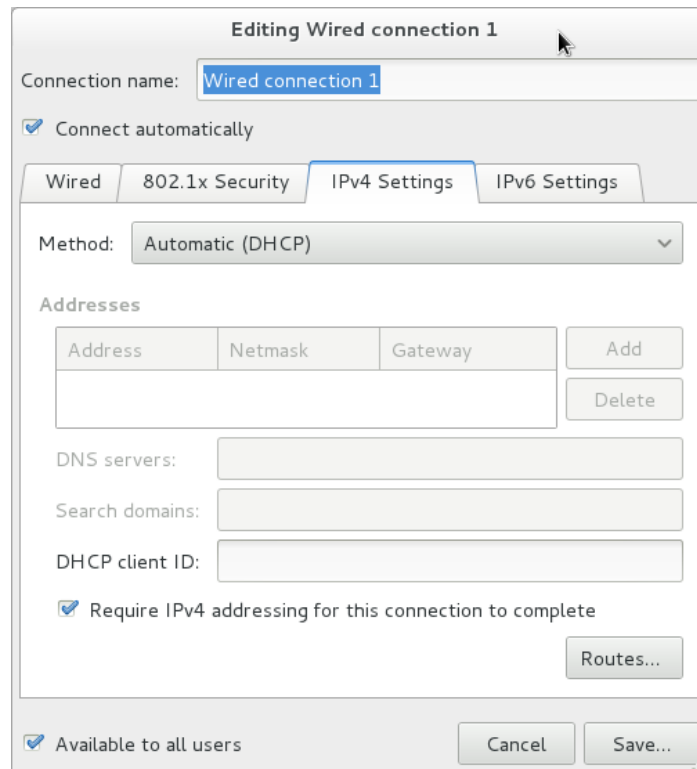

- Select **Automatic (DHCP)** from Method drop down menu.
- Click **Save...**

## **Technical Specifications:**

Standard Compliant	IEEE 802.16e-2005
Air Interface	S-OFDMA
Frequency Band	2.3 – 2.4 GHz (RUT723), 2.5 – 2.7 GHz (RUT725), 3.3 – 3.6 GHz (RUT735) or 3.3 – 3.8 GHz (RUT738)
Channel Bandwidth	3 MHz, 3.5 MHz, 5 MHz, 6 MHz, 7 MHz, 8.75 MHz and 10 MHz
Modulation Adaptive	QPSK, 16QAM, 64QAM
MIMO	MRC, Matrix A + MRC, Matrix B
Beamforming	All I/O Beamforming Items
RF Output Power	2 x 23 dBm @ 3.3 – 3.8 GHz (RUT735, RUT738) or 2 x 25 dBm @ 2.3 – 2.7GHz (RUT723, RUT725)
RX Sensitivity	QPSK1/2: -99 @ 3.5 GHz and 10 MHz BW 16QAM1/2: -93.8 @ 3.5 GHz and 10 MHz BW (RUT735) QPSK1/2: -99.5 @ 2.5 GHz and 10 MHz BW 16QAM1/2: -94.29 @ 2.5 GHz and 10 MHz BW (RUT725)
Antenna Gain	14 dBi dual-pol MIMO
Antenna Type	Panel antenna with pole mounting kit
Handover	Hard / Optimized Handover
QoS Mechanism	UGS, Real-Time-VR, Non Real-Time-VR, Best Effort, ERT-VR
Authentication	EAP-TLS, EAP-TTLS-MSCHAPv2
Encryption	3 CCM-Mode 128-bit AES
Throughput	HARQ UL and DL, up to Category 7 40 Mbps Total DL + UL
LEDs	Power, LAN and WiMAX Activity
LAN	1 x RJ45 10/100 Base-T Ethernet
POE	IEEE 802.3af-2003 Compliant

## **Electrical, Mechanical & Environmental:**

Dimensions (H x W x D)	290mm x 240mm x 45mm
Mounting Pole Diameter	30 – 50 mm
Weight	1.3 kg
Power Supply	36 – 57VDC
Power Consumption	< 6W
Operating Temperature -	- 20° to 50° C
Storage Temperature -	- 20° to 70° C
IP Rating	IP65
Storage Humidity	5% to 95% Non-condensing